

San Patricio Electric Cooperative
S.P.E.C. Electrician (361) 364-2220 Ext. 132
House Mounted Meter Loop Construction Requirements

All installations must comply with the latest applicable National Electrical Code (NEC), local regulations, and Cooperative requirements.

Final approval and service connection are subject to inspection by the Cooperative.

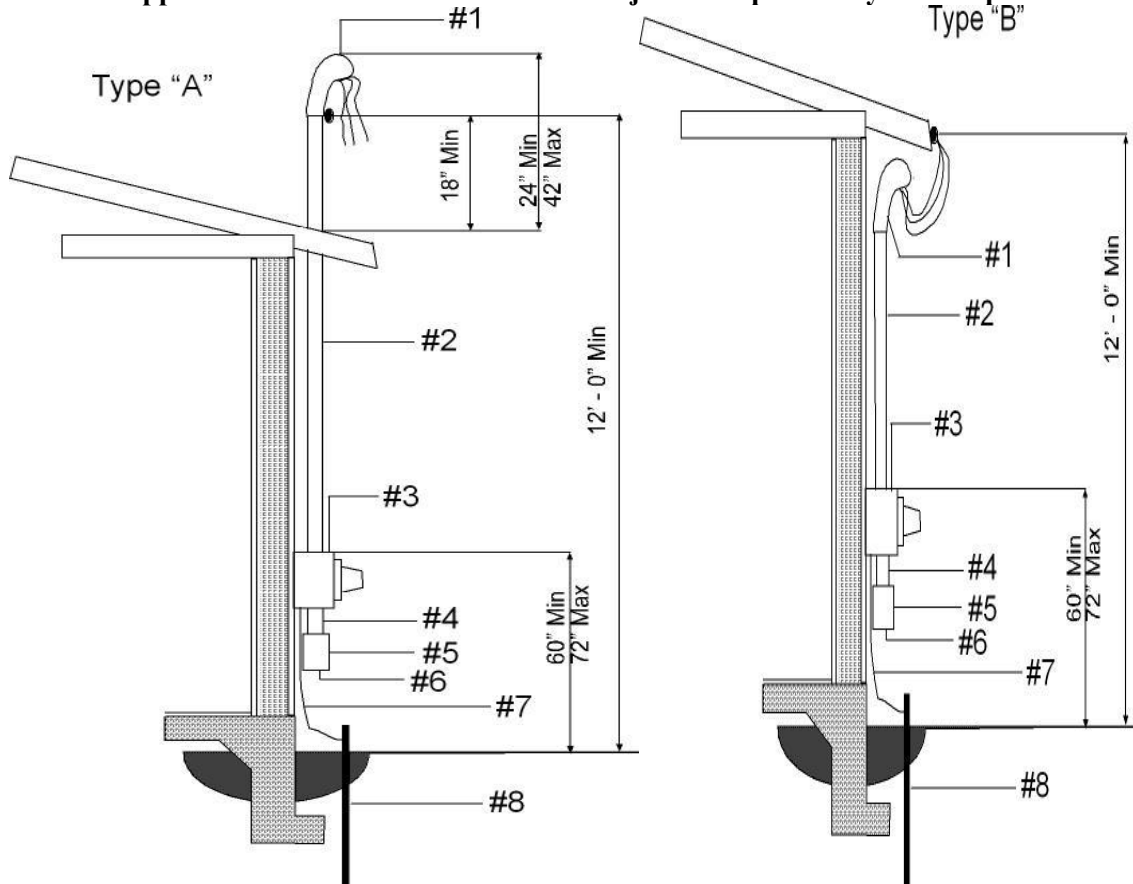

1. Weather Head
2. Rigid Metal Conduit

TYPE "A": Mast type risers shall be a MINIMUM of 2" rigid galvanized conduit, and must be sufficient to support the stress. Risers must pass through eave and extend above the roof by at least 24" but not more than 42". No joint couplings will be allowed above the roof. Wire must extend out of weather head at least 24".

TYPE "B": Riser shall be made of rigid galvanized conduit, rigid aluminum conduit. **(EMT is not acceptable).**

3. Ringless Meter cab should be placed with the top of the meter can at least 60" but no more than 72" from ground level.
4. PVC TA's (Threaded Adapters) with lock rings and plastic bushing from Meter can to panel. If threaded galvanized or aluminum nipple is used, there must be a bonding bushing installed on the meter can side with the ground wire passing through the lug. Panel side must be connected to hub if located below meter can. Conduit must be same diameter as riser conduit above meter can. Length must be a minimum of 4" but not more than 6". Lock rings and plastic bushing are required on all nipples and adapters.
5. Breaker Panel (MUST HAVE MAIN BREAKER).
6. Customers Breakers Optional.
7. Ground Wire #6 green stranded/solid up to 150 amp, #4 green up to 225 amp, #2 green up to 320 amp. Ground wire starts in meter enclosure and passes out to ground rod. From the panel the wire must be in PVC conduit.
8. 5/8" x 8' Copper-Clad Ground Rod & Clamp shall be fully driven into earth with the top of the rod just below the surface of the ground.

San Patricio Electric Cooperative
S.P.E.C. Electrician (361) 364-2220 Ext. 132
House Mounted Meter Loop Construction Requirements

CONSTRUCTION of 3 WIRE METER LOOPS

- A. Wire should be sized according to the Meter loop amp rating. See Chart
- B. Conduit should be sized according to wire size. See Chart
- C. If breaker box is mounted below the Meter Enclosure, a hub is required on the breaker box.
- D. Under no circumstances will a service drop be installed over the top of a house or building structure.
- E. Guidelines on clearances for service conductors as listed on back MUST be followed.

METER LOOPS MUST BE COMPLETELY ASSEMBLED BY THE MEMBER OR BY AN ELECTRICIAN in order to be connected. Cooperative employees will not help in the assembling of a meter loop on the job site. San Patricio Electric has a licensed electrician that builds meter loops and offers other services as well. For a price quote please call the Cooperative at (361) 364-2220 Ext. 132

Top of the Meter Enclosure must be mounted between 60" – 72" from ground level.

Meter and Main Disconnect must be located on the outside area of any structure and must be accessible to the Cooperative and/or fire department. First point of disconnect must be breakers or fuses and not blade disconnects.

ALLOWABLE AMPERAGE OF AN INSULATED CONDUCTOR

Taken from National Electric Code Manual Table 310-16

Copper wire, type THHN max. Temp. 90° centigrade, 600 volt insulation minimum

<u>Wire Size</u>	<u>Meter Loop Size</u>	<u>Conduit Size</u>
#2 cu	125 amp service	1-1/4"
#1 cu	150 amp service	1-1/2"
#2/0 cu	200 amp service	2"
#3/0 cu	225 amp service	2"
#350	320 amp service	3"

Aluminum Wire Not Allowed
Reduced Neutral Not Allowed

Ground Clearance

NOTE: For 120/240-volt service drop installations minimum clearances must be maintained according to SPEC regulations.

- 12' of clearance shall be maintained where no traffic is present.
- 15' of clearance shall be maintained over driveways.
- 22' of clearance shall be maintained over roadways.