

San Patricio Electric Cooperative - 361-364-2220

House-Mounted 320 Amp Meter Loop Construction Requirements

All installations must comply with the latest applicable National Electrical Code (NEC), local regulations, and Cooperative requirements.

Final approval and service connection are subject to inspection by the Cooperative.

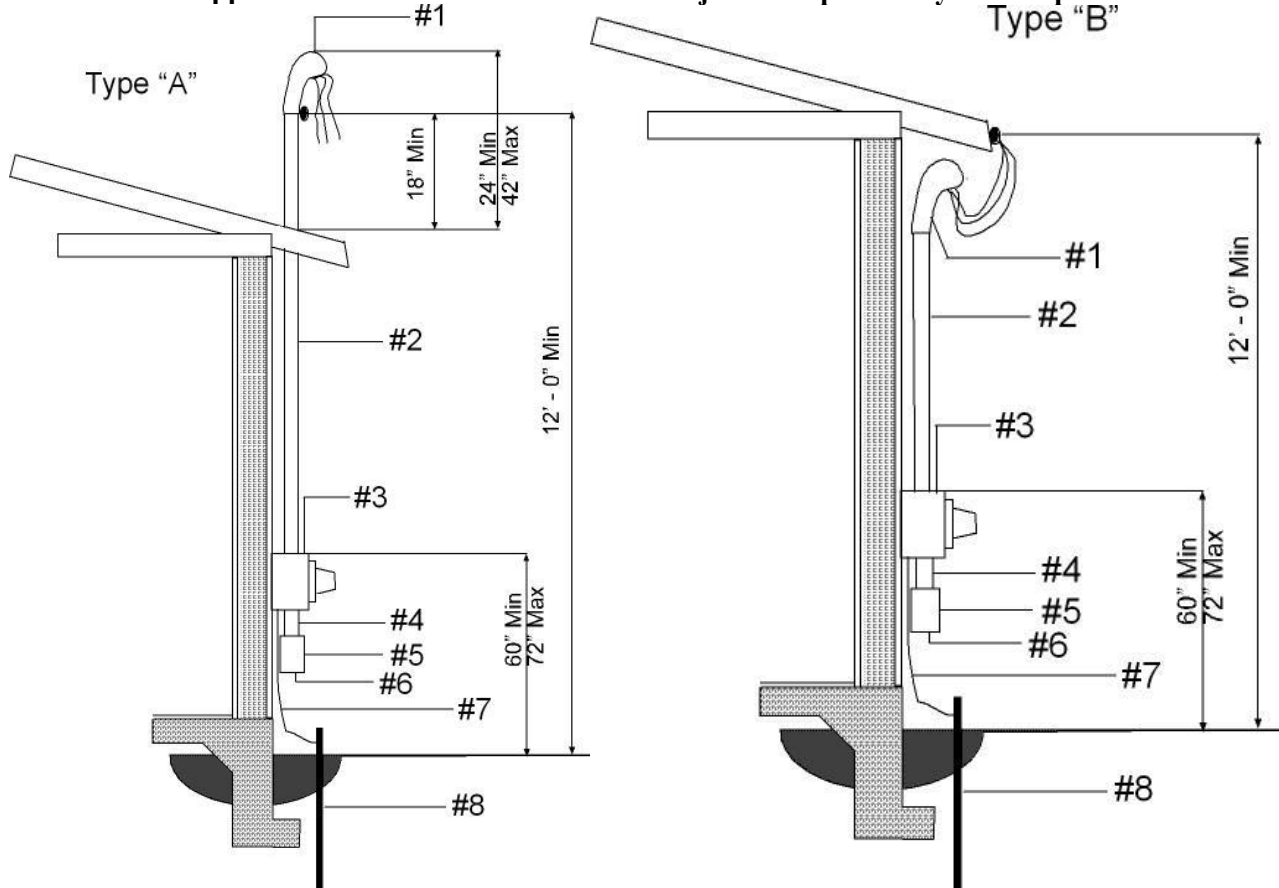

320 Amp Meter Loop

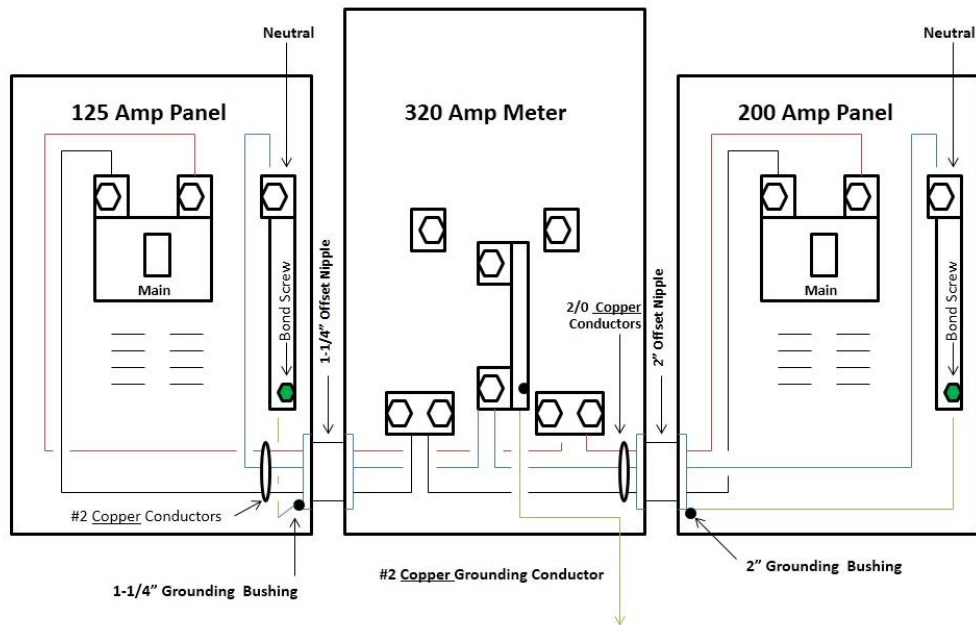

Minimum 5/8" Ground Rod Shall be Below Ground Level

San Patricio Electric Cooperative - 361-364-2220

House-Mounted 320 Amp Meter Loop Construction Requirements

1. 2 ½ - 3” Weather Head
2. Rigid Metal Conduit

TYPE “A”: Mast type risers shall be a MINIMUM of 2 ½” rigid galvanized conduit, and must be sufficient to support the stress. (EMT is not acceptable). Risers must pass through eave and extend above the roof by at least 24” but not more than 42”. No joint couplings will be allowed above the roof. A MINIMUM size of 350 MCM stranded copper wire is required. Wire must extend out of weather head at least 24”.

TYPE “B”: Meter Loop shall be made of rigid galvanized conduit or rigid aluminum conduit. (EMT is not acceptable). A MINIMUM size of 350 MCM stranded copper wire is required. Wire must extend out of weather head at least 24”.

3. Ringless Meter Can should be placed with the top of the meter can at least 60” but no more than 72” from ground level.
4. PVC TA’s (Threaded Adapters) with lock rings and plastic bushing from Meter can to panel. If threaded galvanized or aluminum nipple is used, there must be a bonding bushing installed on the meter can side with ground wire connected to grounding lug. Panel side must be connected to hub if located below meter can. Conduit must be same diameter as riser above meter can. Length must be a minimum of 4” but not more than 6”.
5. Breaker panels must have main breaker/fuses. Service disconnects must only add up to 325amps or below. Above 325 amps see Current Transformer (C.T.) meter loop diagram.
6. Breaker(s) inside breaker box
7. Ground Wire #6 green stranded/solid up to 150 amp, #4 green up to 225 amp, #2 green up to 320 amp. Ground wire starts in meter can and passes out to ground rod. From the panel the wire must be in PVC conduit.
8. 5/8” x 8’ Copper-Clad Ground Rod & Clamp shall be fully driven into earth with the top of the rod just below the surface of the ground.
 - Wire should be sized according to the load. See Chart
 - Conduit should be sized according to wire size. See Chart
 - If breaker box is mounted below the meter can, a hub is required on the breaker box.
 - On Type “B” installation, customer shall provide a point of contact sufficient to support service conductor. Attachment shall be insulated for minimum of 600 volts.
 - Under no circumstances will a service drop be installed over the top of a house or building structure.
 - Guidelines on clearances for service conductors as listed on back, MUST be followed.

METER LOOPS MUST BE COMPLETELY ASSEMBLED BY THE MEMBER OR BY AN ELECTRICIAN in order to be connected. Cooperative employees will not help in the assembling of a meter loop on the job site. San Patricio Electric has a licensed electrician that builds meter loops and offers other services as well. For a price quote please call the Cooperative at 361-364-2220.

CONSTRUCTION of 3 WIRE METER LOOP

Meter loop must be assembled by the member or by an electrician. The Cooperative shall determine the acceptability of the meter loop before the connection is made.

Top of the Meter Can must be mounted between 60” – 72” from ground level.

Meter and Main Disconnect must be located on the outside area of any structure and must be accessible to the Cooperative and/or fire department. First point of disconnect must be breakers or fuses and not blade disconnects.

San Patricio Electric Cooperative - 361-364-2220

House-Mounted 320 Amp Meter Loop Construction Requirements

ALLOWABLE AMPERAGE OF AN INSULATED CONDUCTOR

Taken from National Electric Code Manual Table 310-16

Copper wire, type THHN max. Temp. 90° centigrade, 600 volt insulation minimum

<u>Wire Size</u>	<u>Meter Loop Size</u>	<u>Conduit Size</u>
#2 cu	125 amp service	1-1/4"
#1 cu	150 amp service	1-1/2"
#2/0 cu	200 amp service	2"
#3/0 cu	225 amp service	2"
#350	320 amp service	3"

Aluminum Wire Not Allowed

Reduced Neutral Not Allowed

Ground Clearance

NOTE: For 120/240-volt service drop installations minimum clearances must be maintained according to SPEC regulations.

12' of clearance shall be maintained where no traffic is present

15' of clearance shall be maintained over driveways

22' of clearance shall be maintained over roadways

The measurement for clearance is determined at the lowest point in the service wire. The clearances from the ground to the service wire will decrease as the distance between the house/building and pole increases.